

INDEX

- 1- Positioning the reel
- 2-Tensioning the reel
- 3- Fixing cable
- 4- Connecting cable
- 5- Tensioning added

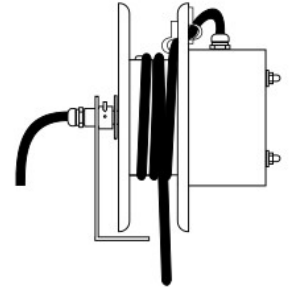
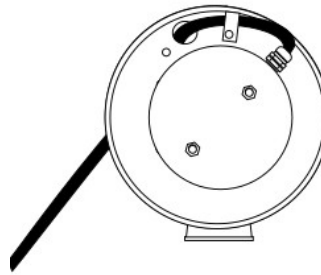

1- Positioning the reel

Before you start,

The FAL6 model can be attached to both the fixed part and the mobile that needs to be powered. It can be fixed either by the two 10mm diameter holes in the bracket or by welding to the structure.

IT IS RECOMMENDED THAT THE MOBILE IS AT THE CLOSEST POINT TO THE CONNECTION POINT.

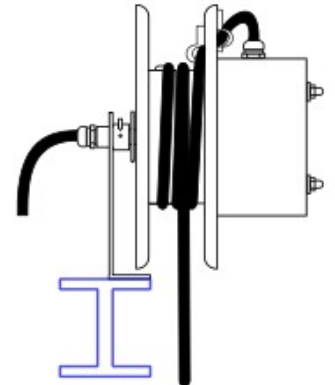
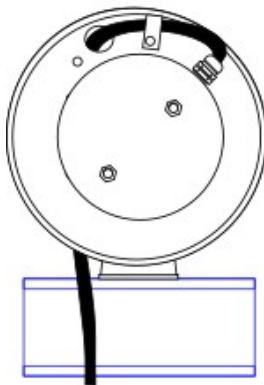
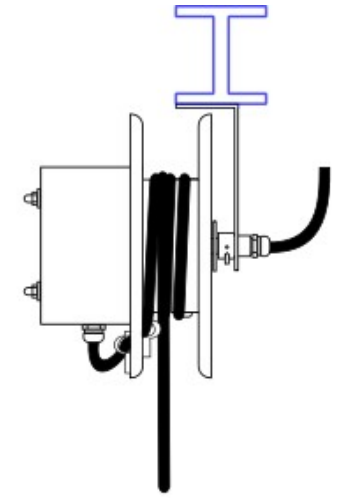
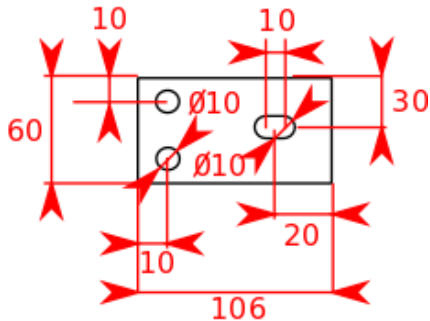
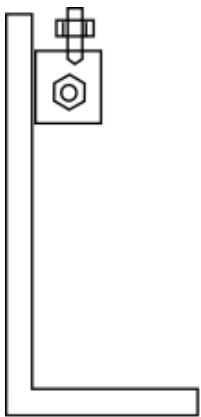

Fixing,

If you want to fix the roller by means of screws using the 10mm. brackets of the bracket, make holes in the surface where you want to fix it beforehand.

Position the roller on the surface where it is to be fixed.

The position of the bracket can be any as long as the axis of the roller is parallel to the floor and perpendicular to the direction of movement.

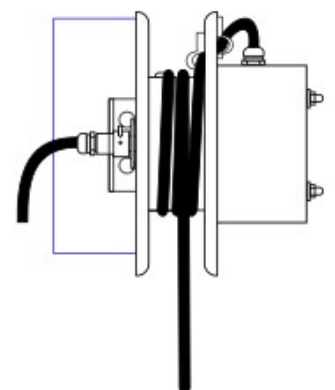
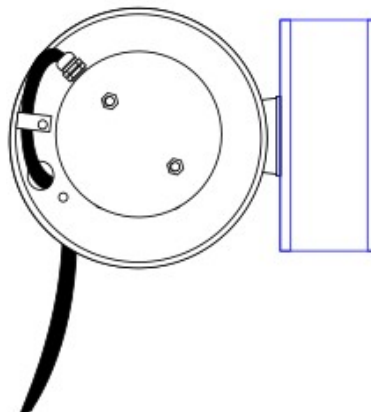

2- Tensioning the reel

The FAL6 reel comes completely untensioned. To tighten it, simply turn it in the direction of the arrow 2 turns (the pictures show 1 turn).

The reel will progressively exert more force against the movement (max. 2Kg).

DO NOT RELEASE THE CABLE DURING THIS PROCESS AS UNCONTROLLED UNWINDING OF THE REEL WILL RESULT IN SPRING FAILURE.

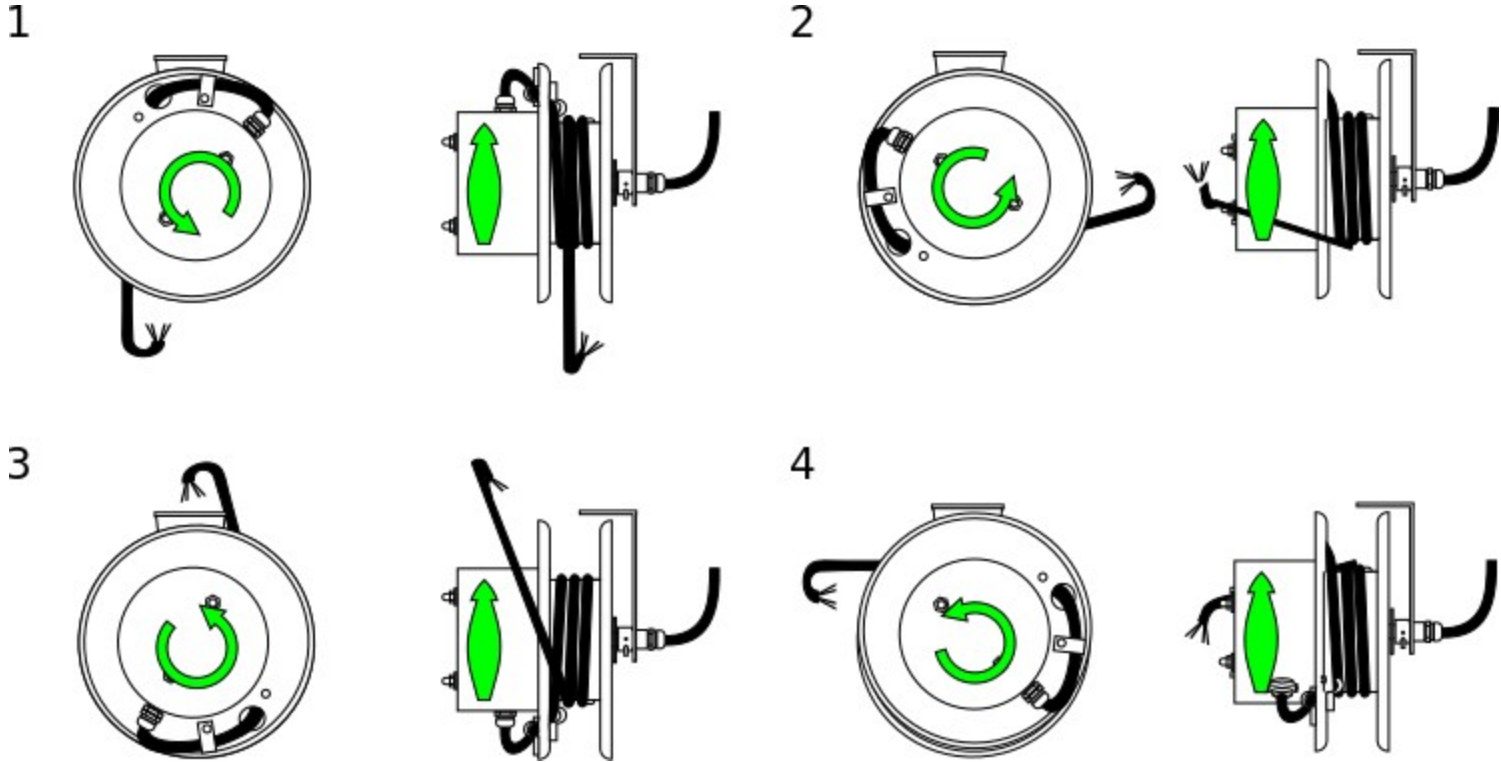

3- Fixing cable

Tirar del cable hasta sujetarlo con la malla o con cualquier sistema de sujeción al punto de anclaje del móvil

Pull the cable until it is fastened with the netting or any other fastening system to the anchorage point of the mobile

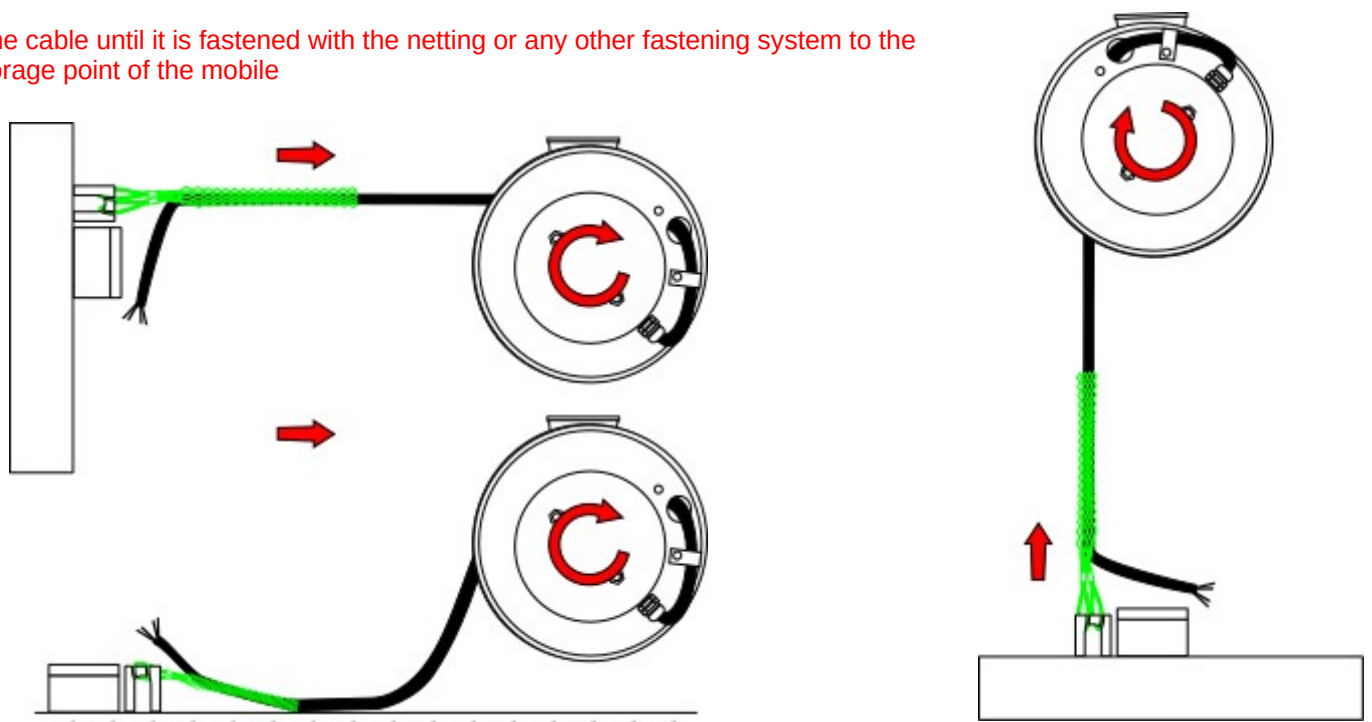

Doc: CTES 0006/0004

3- Connecting cable

The phases can now be connected as the cable is fixed to the anchor point and the reel does not exert any tension on the phases to be connected.

THE RED ARROW INDICATES THE DIRECTION IN WHICH THE CABLE REEL WILL PULL THE CABLE

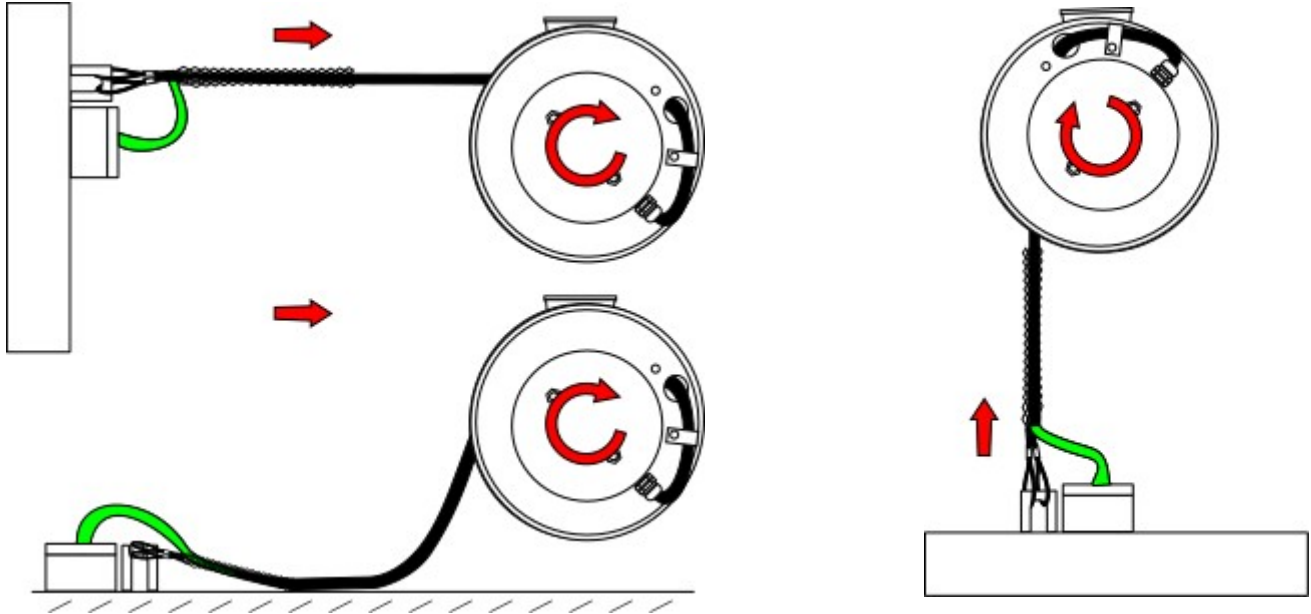

4- Tensioning added

It is possible to increase the tension of the reel after connection by up to 1 more turn if necessary. To tighten it, turn the reel with the cable as shown in the figure.

